



 **MATRIX**[™]

MVX-200

DOYPACK VFFS MACHINE

F&T

**FLEXIBLES
& TRAYS**

MVX-200

DOYPACK VFFS MACHINE

Matrix MVX-200 Doypack

The MVX-200 Doypack Machine is a compact, high-efficiency system designed for flexible vertical form fill seal packaging. It produces stand-up pouches that maximize shelf impact and branding space, while offering consumer-friendly features like recloseable zippers and easy-open options.

Ideal for space-limited facilities, the MVX-200 delivers high output with a small footprint, at a competitive price. With fast, tool-free changeovers, it minimizes downtime and supports quick transitions. It offers premium performance at a competitive price and is built for versatility, capable of running doypack, 3-side seal, quad seal, and block-bottom bag styles, with various fitments on a single machine.

The MVX-200 delivers high-speed output in a compact footprint, and at a competitive price, while supporting a wide range of bag styles and fitments on a single machine.

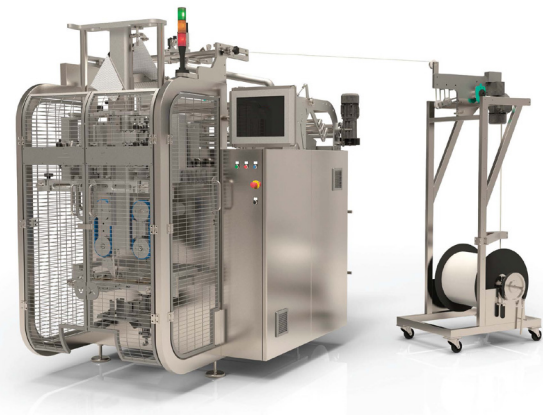

PRODUCT APPLICATIONS



Coffee & Beverages
Ground coffee,
powdered drink mixes



Home & Personal Care
Detergents, soap
refills, powders



Pet Food & Treats
Stand-up pouches for
dry or moist products



Health & Nutraceuticals
Protein powders,
supplements, vitamins



Food & Snacks
Chips, nuts, dried fruits,
candy, grains, pasta

FEATURES & BENEFITS

- Compact footprint maximizes output per square foot
- Fast, tool-free changeovers
- Competitive pricing versus other doypack solutions
- One machine handles multiple bag styles: doypack, 3-side seal, quad seals, and block bottom
- Options for recloseable zippers and easy-open features
- Allen Bradley controls
- Robust, stainless steel, IP66 construction

OPTIONS

- Centering system for printed film
- Second system coil holder assembly
- Modified atmosphere gas injection
- Front and rear label applicator
- Film static elimination
- Bag vibrator
- Easy-open blade
- Strips or twin packs
- Euro-hole punch
- Coding and labeling equipment
- Zipper dispenser
- Product outfeed conveyors
- Inclined version (up to 35°)
- Continuous vertical welder and strip

CONFIGURATION

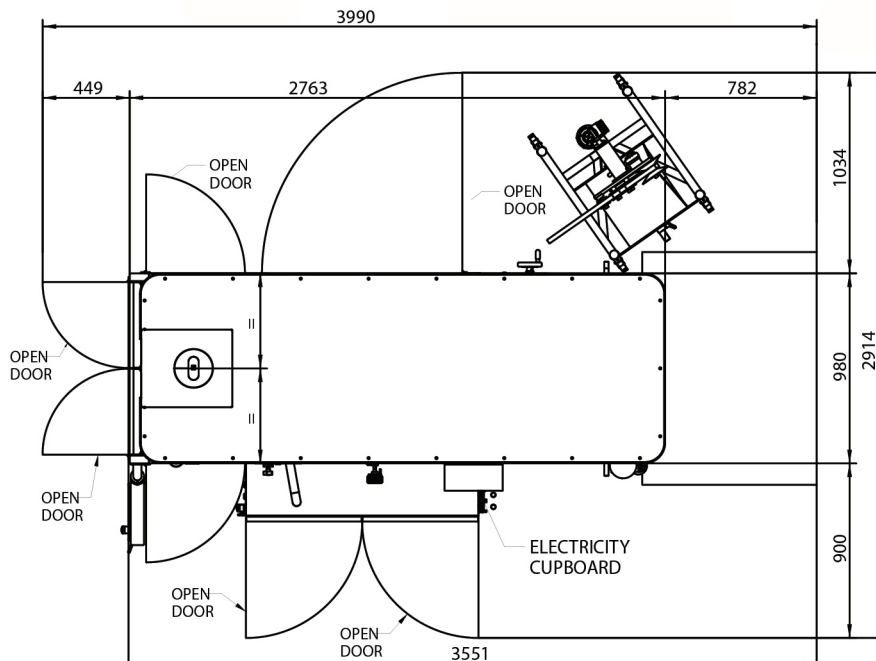
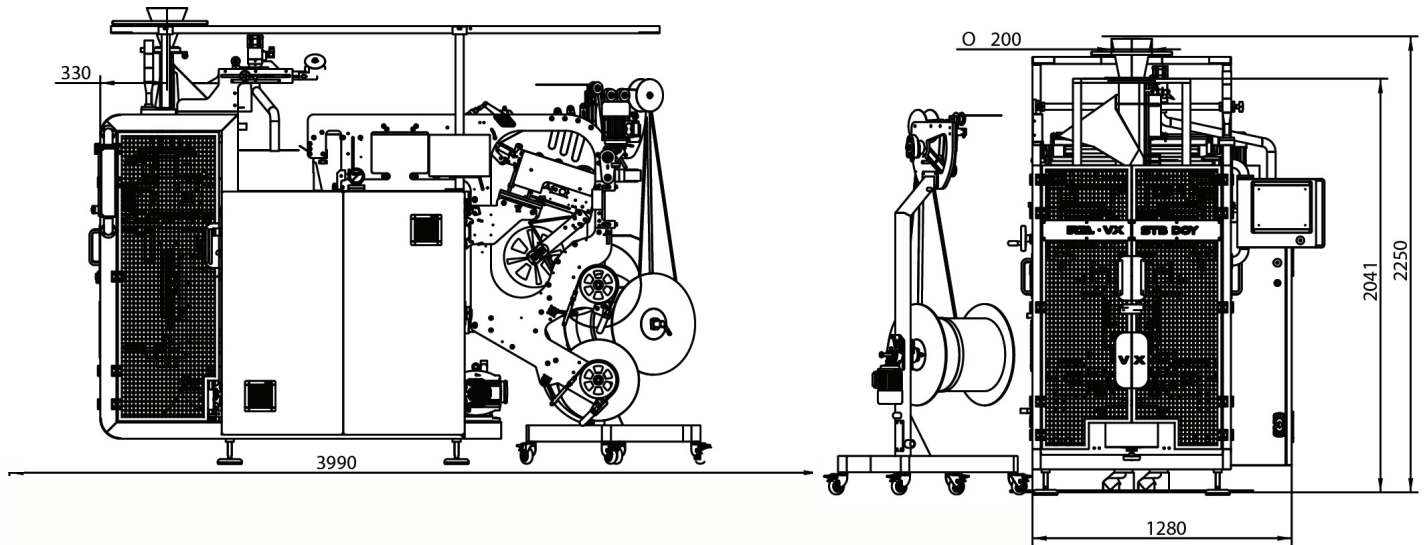

(262) 268-8300

Contact Matrix to learn about packaging machinery tailored to your unique requirements.

DIMENSIONS

Width	2375 mm / 7 ft, 9.5 in
Height	2041mm / 6 ft, 8.25 in
Depth	1560 mm / 5 ft, 1.4 in
Weight	900 kg / 1,984 lbs

MACHINE SPECIFICATIONS

Maximum Output (in vacuum)	110 cycles/min
Energy Consumption	5,5 KVA
Mains voltage	230 / 400 Vca
Air intake	12 NI / Cycle
Finish	Stainless Steel, AISI 316
Air Pressure	80 PSI / 5.5 Bar



About Matrix Packaging Machinery

Matrix is a leading manufacturer of reliable, cost-effective, and easy-to-use vertical form fill seal (VFFS) machines designed for a wide range of flexible packaging applications. As part of ProMach's Flexibles & Trays business line, Matrix enhances its portfolio by partnering with Bartelt and FLtècnics for horizontal form fill seal (HFFS) and cartoning solutions. Bartelt, a trusted manufacturer of pouching, cartoning, and packing solutions, also serves as the master distributor for FLtècnics' rollstock and pre-made pouch machines. Together these brands highlight its innovation in automated packaging, delivering dependable, long-lasting solutions for food and non-food industries.

In addition, Matrix is the master distributor of INVpack stickpack and sachet systems and Pacraft pre-made pouch machines, offering tailored, high-efficiency packaging systems to meet the diverse needs of customers worldwide. Backed by ProMach, a global leader in packaging solutions, Matrix and Bartelt are dedicated to optimizing performance, protecting brands, and fostering trust across the packaging supply chain. Discover more about Matrix at www.MatrixPM.com and ProMach at www.ProMachBuilt.com

MATRIX PACKAGING MACHINERY, LLC
2395 Dakota Drive
Grafton, WI 53024

P: 262-268-8300
TOLL: 888-MATRIX1
E: Matrix.Info@ProMachBuilt.com
MatrixPM.com